

Document Title		Addition of Slip Pads to Rotatub Clutch					
Document #	Rev	Type	Purpose	Recommendation	Original Release Date	Updated Date	
ZSB-016	C	Service Bulletin	Reliability Improvement	Optional	10-28-2015	01-19-2024	

## Addition of Slip Pads to Rotatub Clutch



Zephyr International LLC

5015 Enoch Rd, Conway SC 29526 USA

Phone 843-365-2675 \* Fax 843-365-2677

Email: [info@zephyrintl.com](mailto:info@zephyrintl.com)

Web: [www.zephyrintl.com](http://www.zephyrintl.com)

Serving Helicopter Rescue Hoist Users Worldwide

Prepared by	Michael R Mitchell	<a href="mailto:mmitchell@zephyrintl.com">mmitchell@zephyrintl.com</a>
Checked by	Victoria Mitchell	<a href="mailto:vmitchell@zephyrintl.com">vmitchell@zephyrintl.com</a>
Approved by	Elizabeth Bielsa-Mitchell	<a href="mailto:zephyradmin@zephyrintl.com">zephyradmin@zephyrintl.com</a>
Purpose	Reliability Improvement	
Recommendation is Mandatory or Optional	Optional	

Document Title		Addition of Slip Pads to Rotatub Clutch					
Document #	Rev	Type	Purpose	Recommendation	Original Release Date	Updated Date	
ZSB-016	C	Service Bulletin	Reliability Improvement	Optional	10-28-2015	01-19-2024	

**Purpose:** To alert the Users of a reliability upgrade that adds permanently lubricated slip pads to the Rotatub clutch.

**Reason:** The Rotatub clutch originally had been lubricated by a thin film of grease. By using two permanently lubricated Delrin pads instead of grease a more consistent slipping value can be obtained and the need for re-lubrication is eliminated.

**Applies to units produced prior to:**

- M01290415 Manual RHGSE and higher all have the slip pads incorporated.
- E00040715 Electric RHGSE and higher all have the slip pads incorporated.
- H02020815 Hydraulic RHGSE and higher all have the slip pads incorporated.

**Procedure: Installation of ZGS-10737-1 slip pads, required quantity (2)**

1. Remove the Rotatub and Spooler by removing the ¼-20 lock nuts (4).

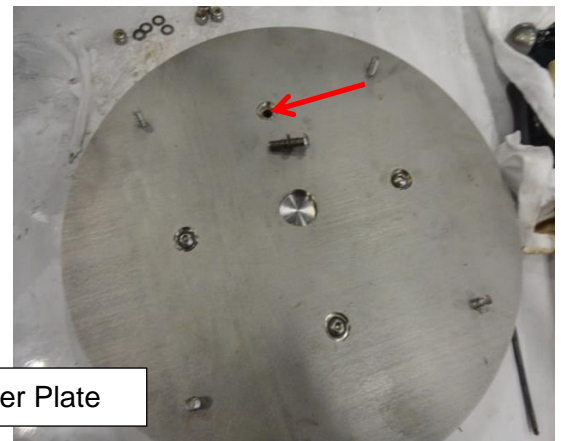

Upper Plate

2. Using a 7/16 Box wrench and a 5/32 hex key remove the ¼-28 bolts (4), being careful to note the position and orientation of the Belleville washers.
3. Disassemble the platen assembly and clean all the grease off the upper plate.

Document Title		Addition of Slip Pads to Rotatub Clutch					
Document #	Rev	Type	Purpose	Recommendation	Original Release Date	Updated Date	
ZSB-016	C	Service Bulletin	Reliability Improvement	Optional	10-28-2015	01-19-2024	

- Remove the (4) Flat head screws that attach the bronze disc to the axel shaft, in order to remove the bronze disc. Use of an impact tool may be required.

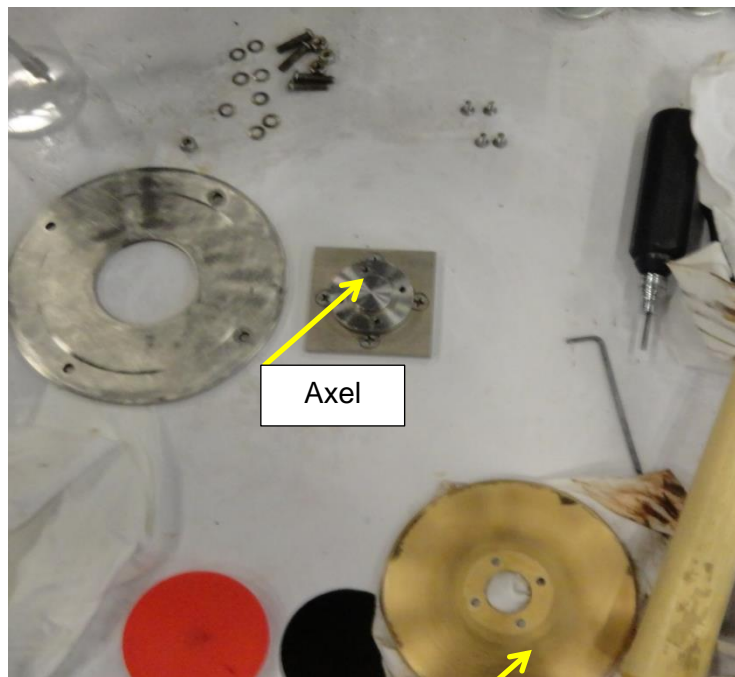
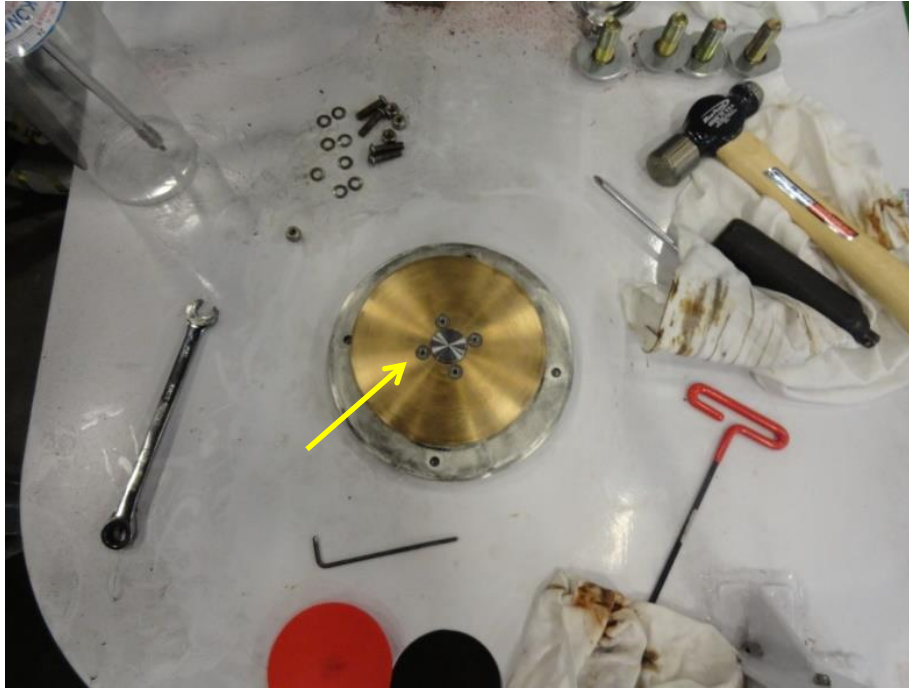

- Remove all the grease from the bronze disc.

Document Title		Addition of Slip Pads to Rotatub Clutch					
Document #	Rev	Type	Purpose	Recommendation	Original Release Date	Updated Date	
ZSB-016	C	Service Bulletin	Reliability Improvement	Optional	10-28-2015	01-19-2024	

6. Reassemble the platen assembly as follows:
7. Lay the lower plate down over the axel shaft with the worn surface upwards.

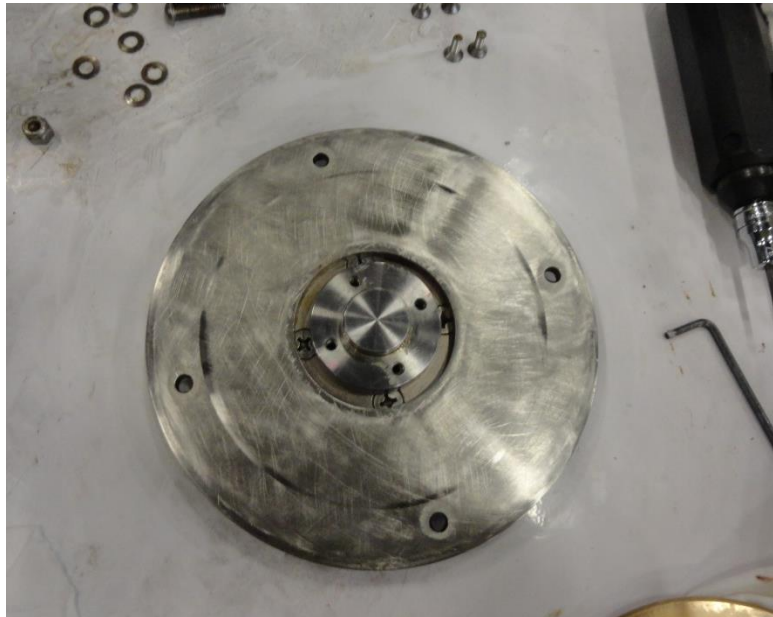

8. Next place a slip pad over it.

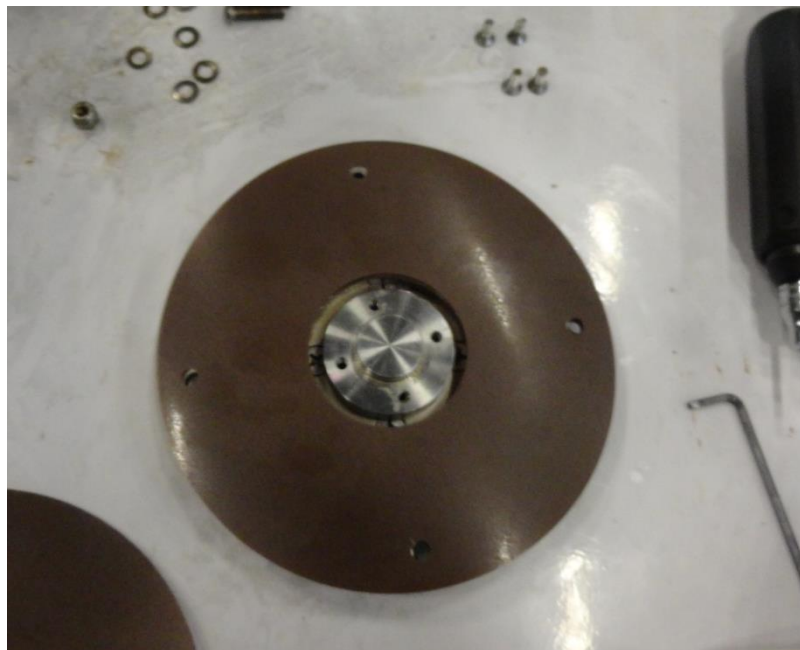

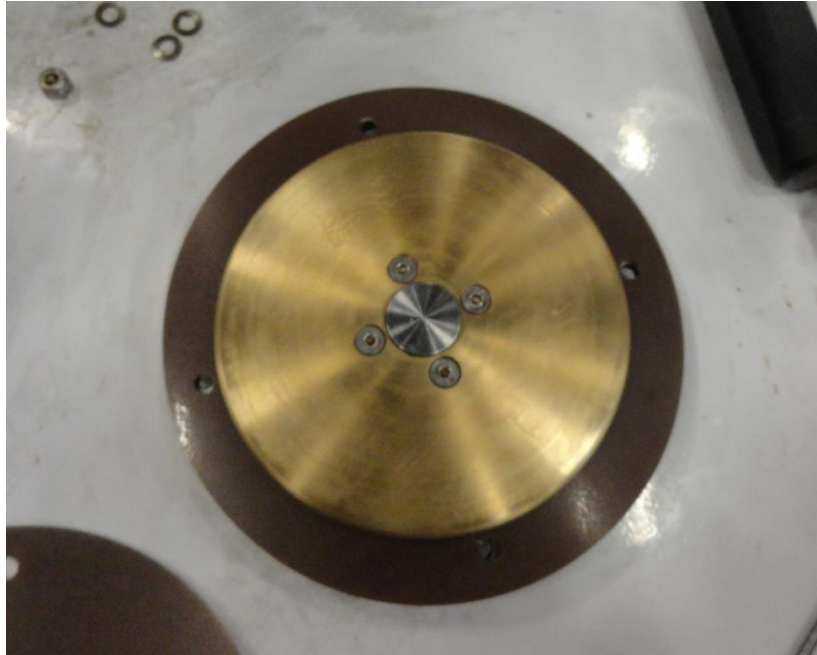

Document Title		Addition of Slip Pads to Rotatub Clutch					
Document #	Rev	Type	Purpose	Recommendation	Original Release Date	Updated Date	
ZSB-016	C	Service Bulletin	Reliability Improvement	Optional	10-28-2015	01-19-2024	

9. Then attach the bronze disk with the 4 flat head screws, using Loctite 242.

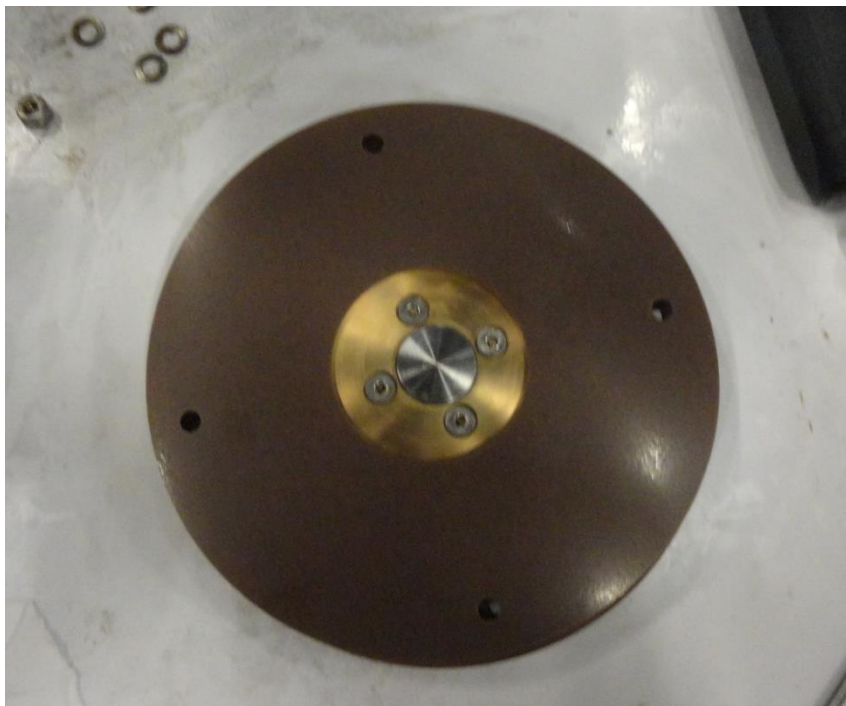

10. Place the next slip pad on top of the bronze disc and align the holes in the plate with the holes in the slip pads.



Document Title		Addition of Slip Pads to Rotatub Clutch					
Document #	Rev	Type	Purpose	Recommendation	Original Release Date	Updated Date	
ZSB-016	C	Service Bulletin	Reliability Improvement	Optional	10-28-2015	01-19-2024	

11. Place the top plate and align the holes.
12. Place a Belleville washer on each ¼ -28 screw with the convex side up and insert them into the holes.

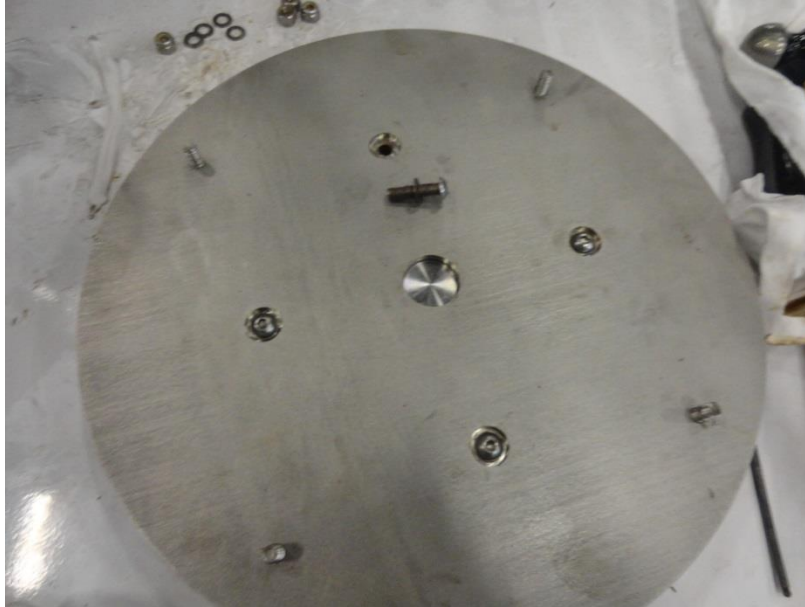

13. Place a Belleville washer on top each lock nut convex side down and attach the nut to each screw from below the lower plate.
14. Carefully tighten the nuts in a crisscross pattern until they just start to tighten.
15. Use a torque watch to check the screws after tightening. Each screw should be able to freely rotate with a torque of 10-14-inch ounces.
16. Torque Watch Part # from McMaster-Carr - # 5699A19 & 5/32 hex bit 1/4 drive #8526A66

Document Title		Addition of Slip Pads to Rotatub Clutch					
Document #	Rev	Type	Purpose	Recommendation	Original Release Date	Updated Date	
ZSB-016	C	Service Bulletin	Reliability Improvement	Optional	10-28-2015	01-19-2024	

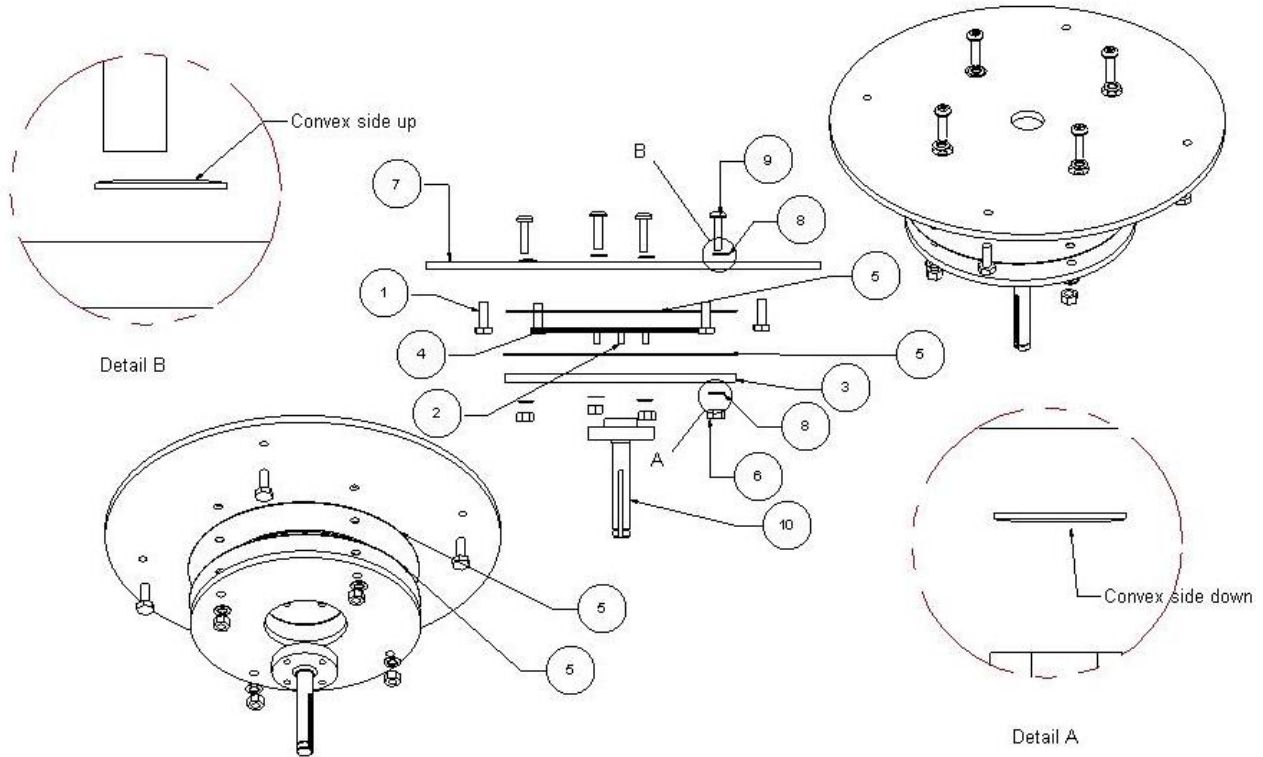

Item Number	Quantity	Part Number	Part Name	Revision	Comment
1	4	129	.25 x .75 cap screw		
2	4	10-32 x 1/2	10-32 Flat Head .5 long		
3	1	ZGS-10176-2	Infinitely adjustable Lower plate		
4	1	ZGS-10175-2	Infinitely Adjustable Platten Plate		
5	2	ZGS-10737-1	Infinitely adjustable Slip Pad		
6	4	2554	.25 Lock nut		
7	1	ZGS-10180-2	Infinitely Adjustable Platten Top Plate		
8	8	87779237	Belleville Washer		
9	4	ANSI B18.6.3	1-4 x 28 x 1 machine screw		
10	1	ZGS-10020-1	Axel		

If a torque watch is not available, then carefully tighten the screws and measure the breakaway torque of the platen with a 0-10 lbs. spring scale.

Document Title		Addition of Slip Pads to Rotatub Clutch					
Document #	Rev	Type	Purpose	Recommendation	Original Release Date	Updated Date	
ZSB-016	C	Service Bulletin	Reliability Improvement	Optional	10-28-2015	01-19-2024	

17. Adjust the (4) ¼-28 screws so that when the clutch just starts to slip the value when measured at the (4) ¼-20 bolts used to attach the Rotatub is 3-4 lbs. Measure the slip value at all four screws using a 0-10 lbs. scale.

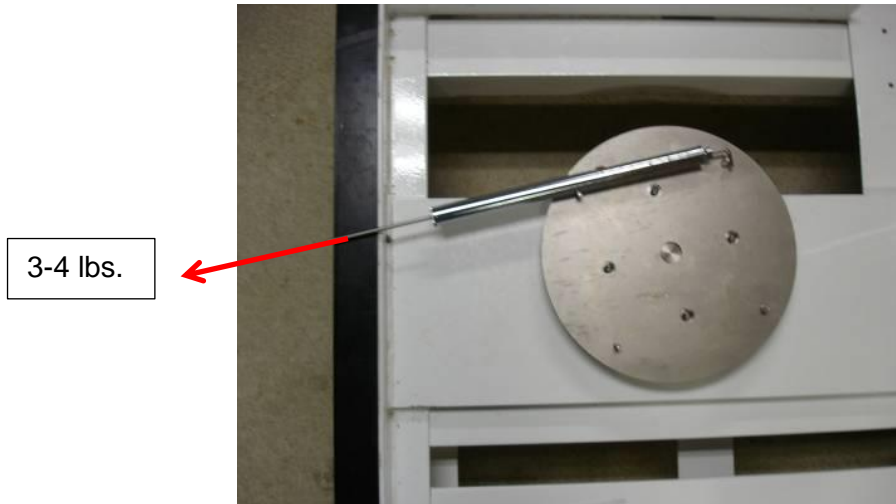

18. The final check is made with the Rotatub reattached to the platen. Use a spring scale to hold the tub while the extend switch is actuated. The force at the tangent to the tub edge should be 2 to 3 lbs. with the slip pads slipping.



**Price / Availability:** Contact Zephyr International for information.